

TOKTÖMÍTÉS-JAVÍTÓ

DUPLA

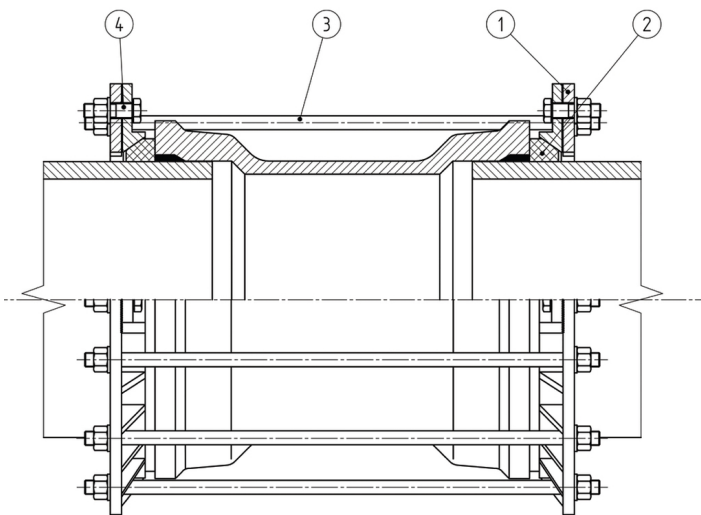
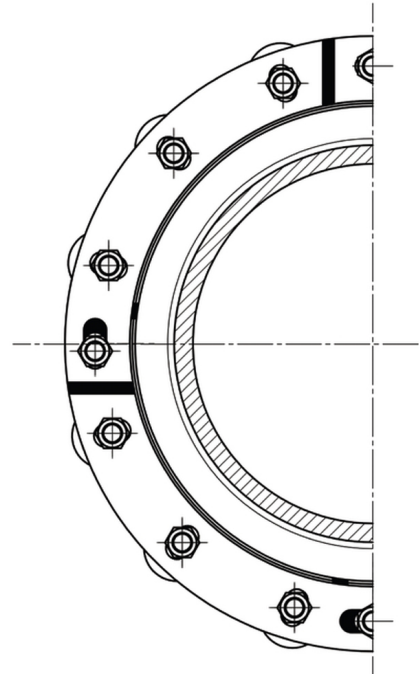
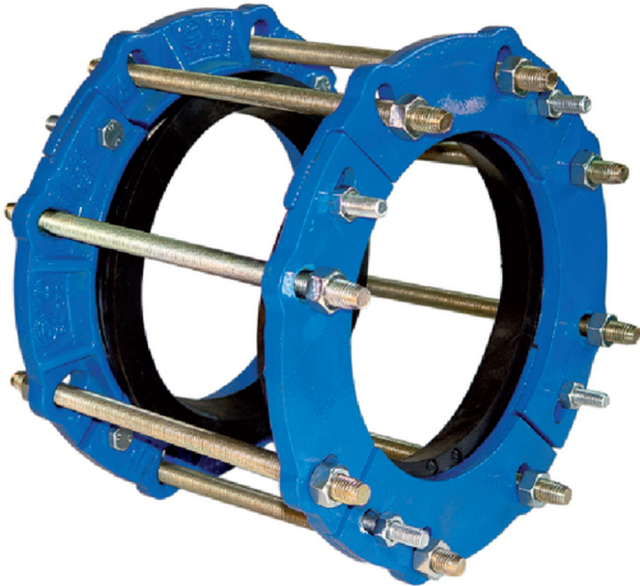

Fő tulajdonságok

Felhasználási terület

- Ivóvízre
- Azbesztcement csövek kötéseinek javítására

Mérettartomány

DN50 - DN1200

Test anyaga

Gömbgrafitos öntöttvas

Bevonat

Epoxipor-bevonat

Csavarok

Rozsdamentes acél A2

Anyák

Rozsdamentes acél A4

Tömítés

EPDM gumi

DN	Cikkszám	Átfogás (mm) Dmin - Dmax	Csavarok		Kötőrudak száma	Szegmensek száma (x2)
			db	méret		
50		63-70	4	M12	4	2
60		72-80	6	M12	6	3
80	70901670108000	98-104	6	M12	6	3
100	709016702100000	118-124	6	M12	6	3
125		144-154	6	M12	6	3
150	709016704150000	170-180	6	M12	8	3
175	709016704175000	196-212	8	M12	8	4
200	709016706200000	222-238	8	M12	8	4
225		248-246	8	M12	12	4
250	70901670827500A	274-292	8	M14	12	4
275	70901670827500B	304-322	8	M14	12	4
300	709016711300000	326-344	8	M16	12	4
325	709016711325000	355-370	8	M16	16	4
350		378-396	8	M16	16	4
400	709016712540000	429-455	10	M16	15	5
425	709016714425000	455-475	10	M16	15	5
450	709016714450000	480-510	10	M16	15	5
500	70901671500-E	532-560	10	M16	20	5
600	70901671600-E	634-662	20	M16	25	5
625		645-670	24	M16	25	6
650	709016725650000	690-715	24	M16	25	6
700		738-768	24	M16	24	6
750	709016735750000	814-840	32	M16	25	8
800		842-882	32	M16	32	8
1000		1048-1090	36	M16	36	9
1200		1256-1298	40	M16	40	10